

PARALLEL ARM INSTALLATION

Closer mounted on door on push side

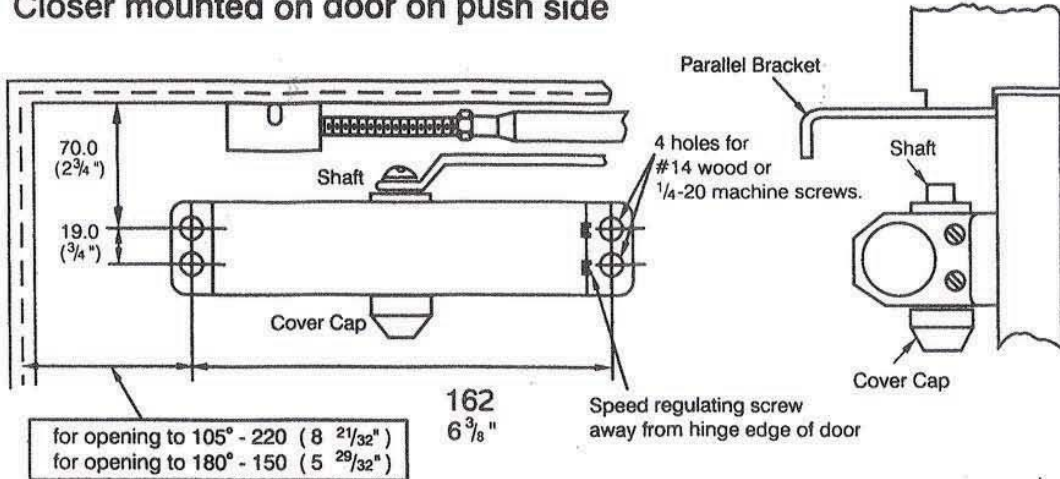

for opening to 105° - 220 (8 21/32")
for opening to 180° - 150 (5 29/32")

for opening to 105° - 230 (9 1/16")
for opening to 180° - 160 (6 19/64")

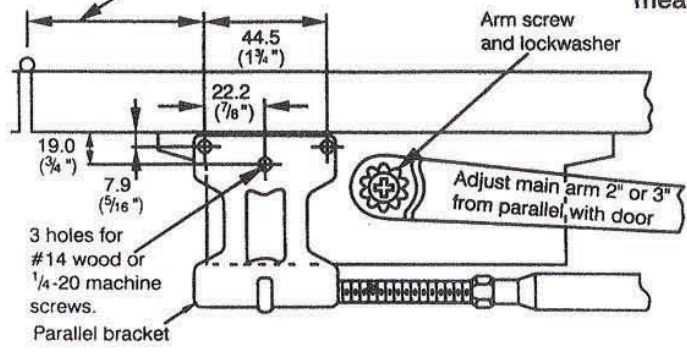

LEFT HAND DOOR shown. Same dimensions apply for right hand door measured from hinge edge.

POSITION OF ARMS AND INDEX SETTINGS

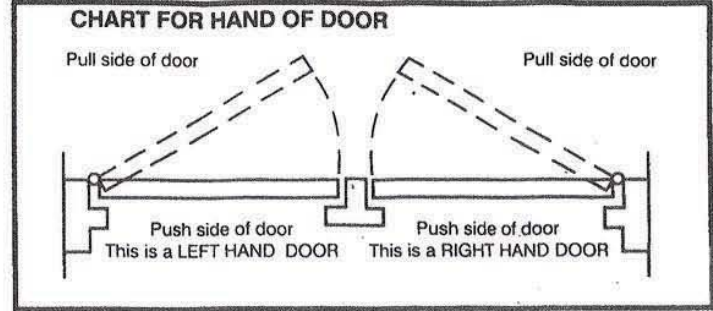
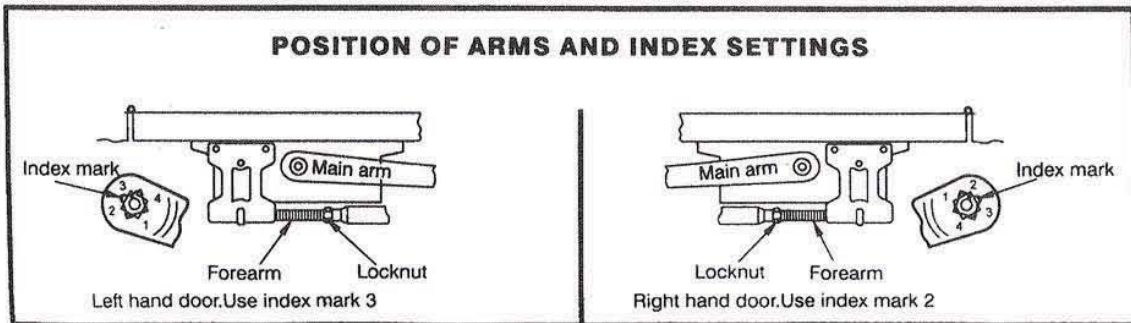

INSTRUCTIONS

Step 1

- A. Check hand of door.
- B. Select type of installation.

Step 2

- A. See instructions for installation you have selected.
- B. Follow instructions for correct application and adjustment.

Step 3

- A. Apply closer body and forearm (or parallel bracket and forearm) to door and frame as shown.
- B. Place main arm on shaft at proper index mark as shown and tighten arm screw with lockwasher securely.
- C. Adjust length of forearm as shown and attach to main arm at elbow and tighten locknut.

Step 4

- Snap cover cap over shaft at unused side.

Step 5

- Door closing and latching speeds are controlled by # 1, # 2 speed regulating screw separately.

- A. Clockwise turns slow the Speed.
- B. Counterclockwise turns increase the speed.

